

EIDOS *pro*

TECHNICALS

Scrivanie con piani e gambe in legno
 Desks with wooden tops and structures
 Mesa con sobres y patas en melamina
 Bureaux avec plateaux et pieds panneaux en mélamine

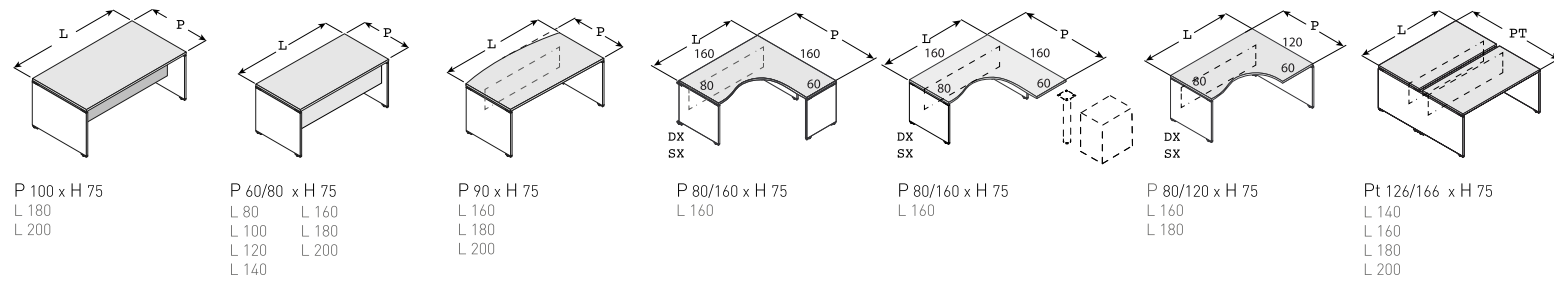

Scrivanie con piani in legno e gambe in metallo fisse
 Desks with melamine tops and fixed metal legs
 Mesas con sobres de melamina y patas metálicas
 Bureaux avec plateaux en mélamine et pieds métalliques fixes

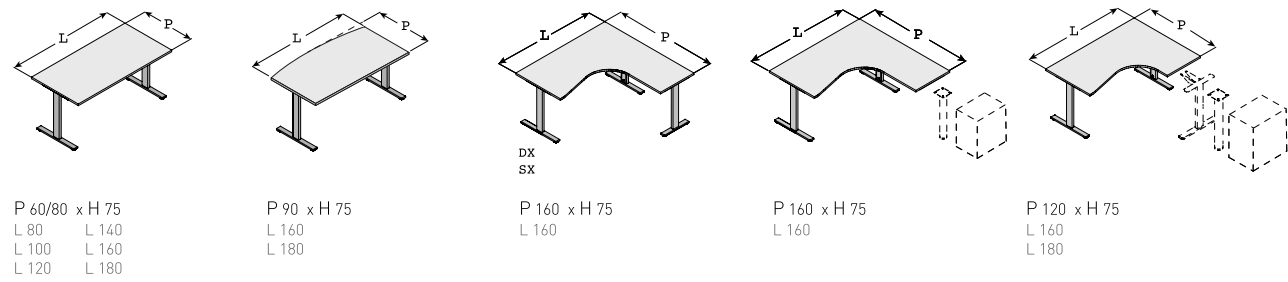

Appendici per scrivanie con gambe in legno.
 Desk extension with melamine paneled leg
 Alas auxiliares para mesas con patas en melamina
 Retour pour bureaux pieds panneaux en mélamine

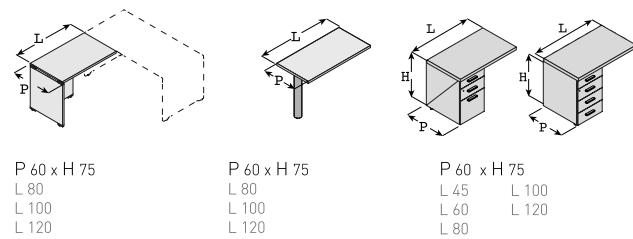

Appendici per scrivanie con gambe in metallo fisse.
 Extensions for desks with fixed metal legs
 Alas auxiliares para mesas con patas metálicas
 Retour pour bureaux avec pieds métalliques fixes

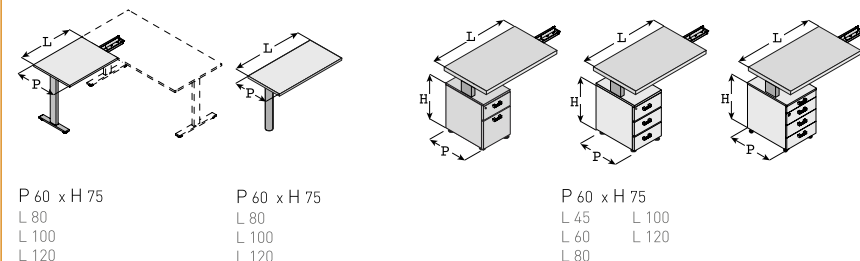

Scrivanie con piani in legno e gambe in metallo selezionabili
 Desks with melamine tops and selectable metal legs
 Mesas con sobres de melamina y patas metálicas ajustables
 Bureaux avec plateaux en mélamine et pieds métalliques réglables par vis

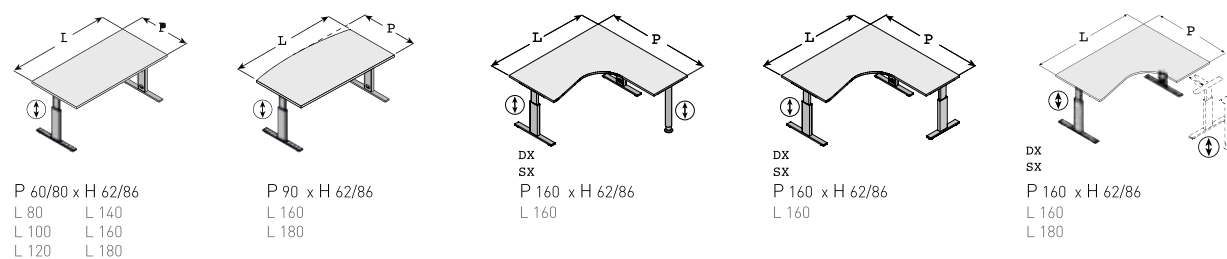

Appendici per scrivanie con gambe in metallo selezionabili.
 Extensions for desks with melamine tops and selectable metal legs
 Alas auxiliares para mesas con patas metálicas ajustables
 Retour pour bureaux avec pieds métalliques réglables par vis

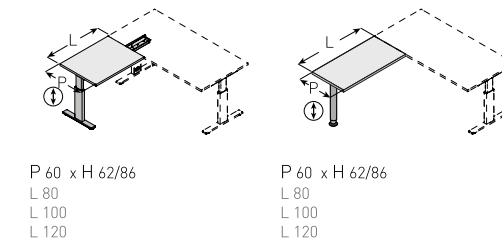

Tavolo ribaltabile e Accessori
 Folding table and accessories
 Mesa con tapa abatible y accesorios
 Table abattante et accessoires

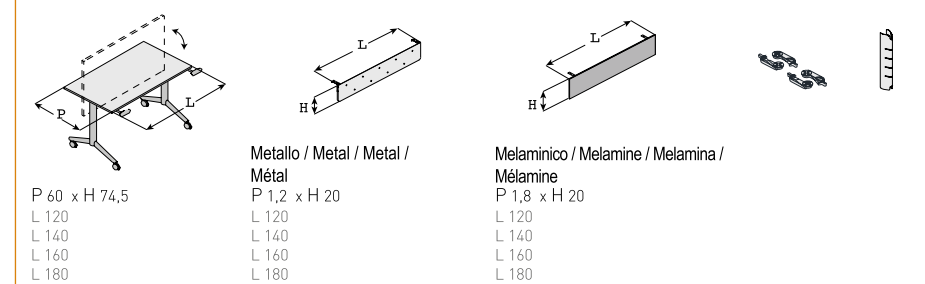

Scrivanie con piani in legno e gambe in metallo elevabili elettricamente
 Desk with melamine tops and metal legs elettrically adjustable
 Mesa con sobres de melamina y patas metálicas regulables en altura eléctricamente
 Bureaux avec plateaux en mélamine et pieds métalliques réglables électriques

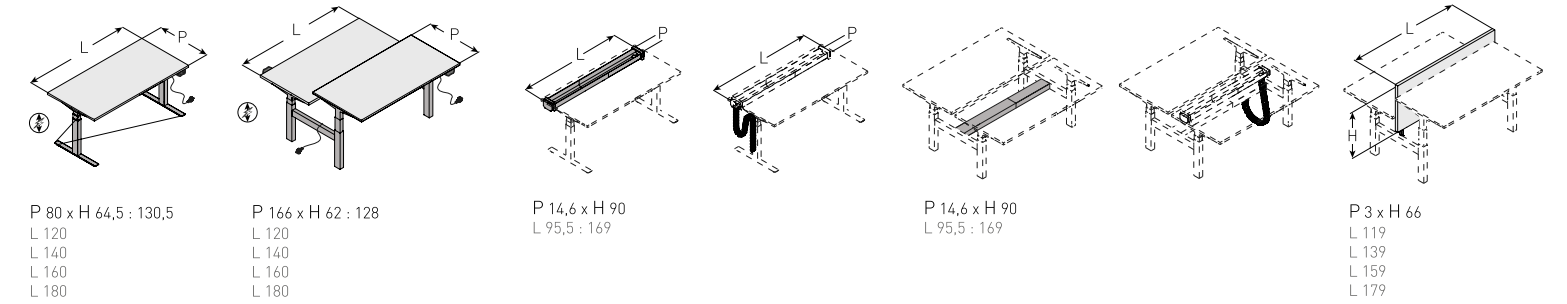

Schermi frontali melaminici o rivestiti, totali e parziali
 Frontal screens, melamine or fabric, full or partial
 Separadores frontales en melamina o tapizado, longitud total y parcial
 Ecrans frontaux mélamine ou tissu, partiels ou toute longueur

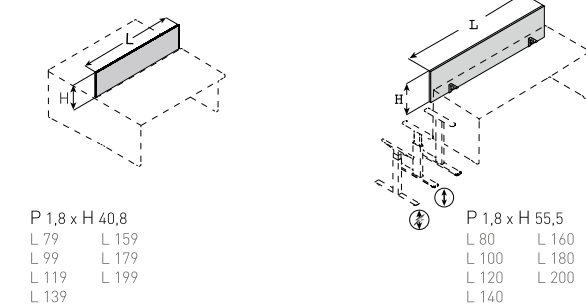

Schermi laterali melaminici o rivestiti
 Side melamine or fabric screens
 Separadores laterales en melamina o tapizado
 Ecrans latéraux mélamine ou tissu.

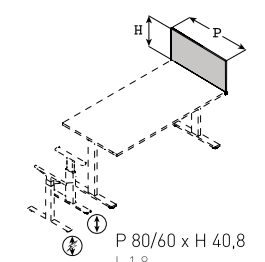

Schermi frontali fonoassorbenti totali e parziali
 Sound proof screens, full or partial
 Separadores frontales fonoabsorbentes, longitud total y parcial
 Ecrans frontaux phoniques partiels ou toute longueur

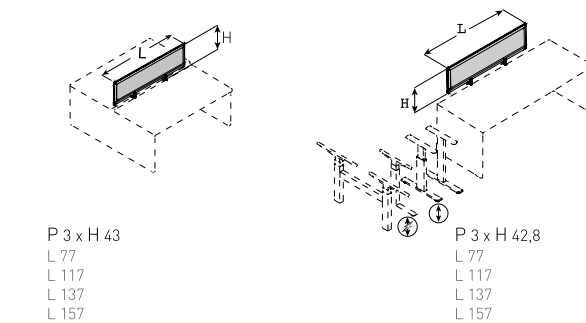

Gonna
 Modesty panel
 Faldones
 Voile de fond

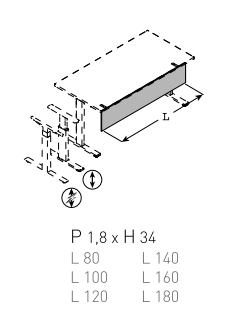

Canalizzazioni e complementi
Cable management systems and accessories
Canalizaciones y complementos
Câblage et accessoires

Angoli di raccordo
Junction angles
Ángulos de unión
Angles de jonction

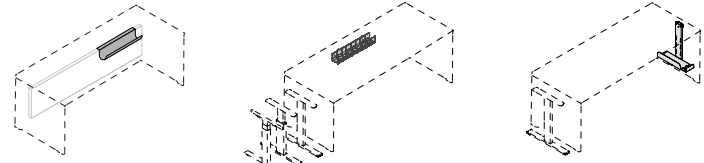

P 11 x H 8,5
L 35
L 65

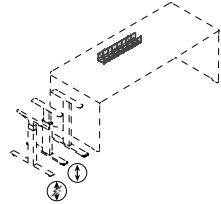

P 16,5 x H 12,5
L 59,1
L 78,7
L 98,3

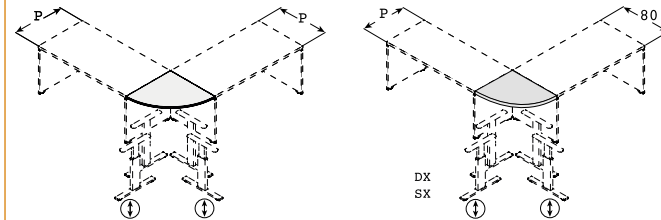

P 80 x H 3
L 80

P 60 x H 3
L 80

Appendici complanari
Complanar extensions
Extensiones complanares
Retours

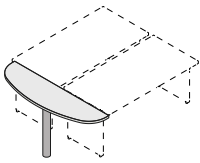

P 45 x H 74,4
L 126
L 166

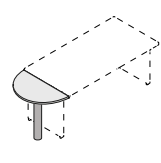

P 40 x H 74,4
L 80

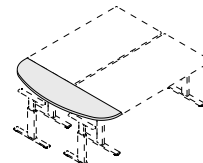

P 45 x H 3
L 126
L 166

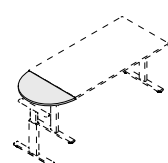

P 40 x H 3
L 80

Tavoli riunione
Meeting tables
Mesas de juntas
Tables réunion



Ø120 x H 75

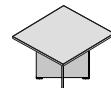

P 110 x H 75
L 110
L 140

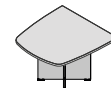

P 110 x H 75
L 110

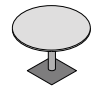

Ø120 x H 74,5

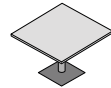

P 110 x H 74,5
L 110
L 140

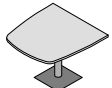

P 110 x H 74,5
L 110

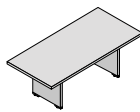

P 110 x H 75
L 220
L 250

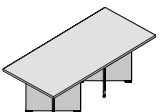

P 110 x H 75
L 220
L 250

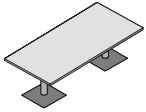

P 110 x H 74,5
L 220
L 250

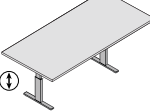

P 110 x H 75
L 220
L 250

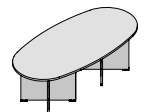

P 110 x H 75
L 220

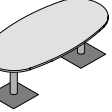

P 110 x H 74,5
L 220

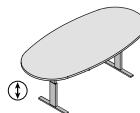

P 110 x H 75
L 220

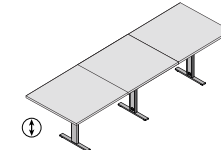

P 110 x H 75
L 360

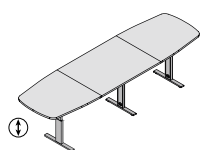

P 110 x H 75
L 360

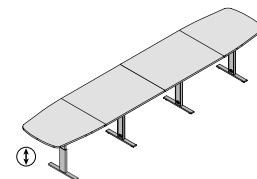

P 110 x H 75
L 500

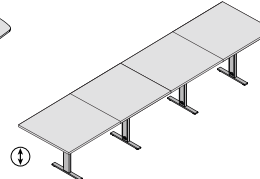

P 110 x H 75
L 500

Paretine
Partitions
Separadores a suelo
Cloisons

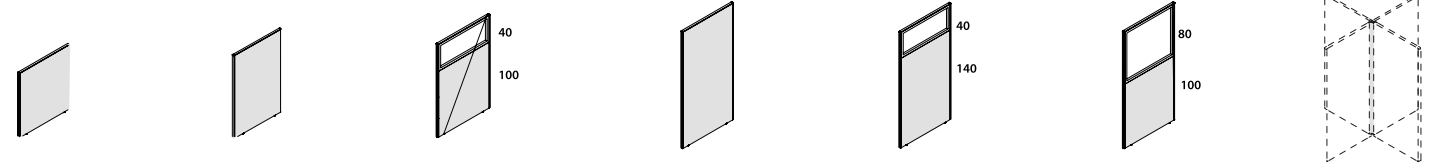

P 3 x H 100
L 60
L 80
L 90
L 100

P 3 x H 140
L 60
L 80
L 90
L 100

P 3 x H 140
L 80
L 100

P 3 x H 180
L 60
L 80
L 90
L 100

P 3 x H 180
L 80
L 90
L 100

P 3 x H 180
L 80
L 90
L 100

P 3 x L 3
L 100
L 140
L 180

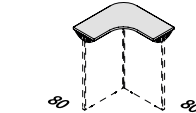

P 32 x H 3
L 97,5x97,5

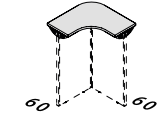

P 32 x H 3
L 77,5x77,5

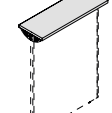

P 32 x H 3
L 80 L 140
L 90 L 160
L 100 L 180
L 120 L 200

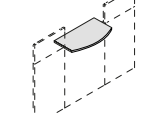

P 45 x H 3
L 60
L 80
L 90
L 100

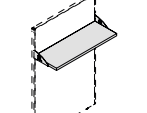

P 32 x H 3
L 60
L 80
L 90
L 100

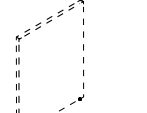

P 25 x H 8
L 12

Cassettiere e mobile di servizio
Pedestal and Service cabinet
Cajonera y Mueble auxiliar
Caisson et Meuble de service

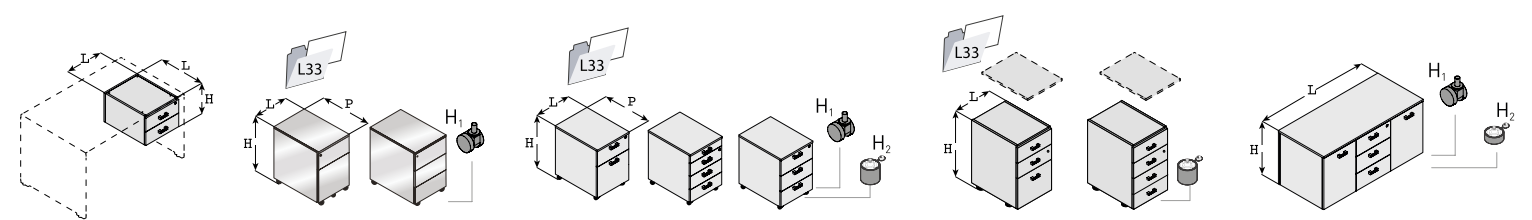

P 52,5 x H 31,5
L 42

P 53,5 x H 55,5
L 42

P 56 x H1/ H2 60
L 42

P 60 x H 72
L 42,5

P 55 x H+H1=58; H+H2= 60,5
L 120

Lockers
Lockers
Taquillas
Casier

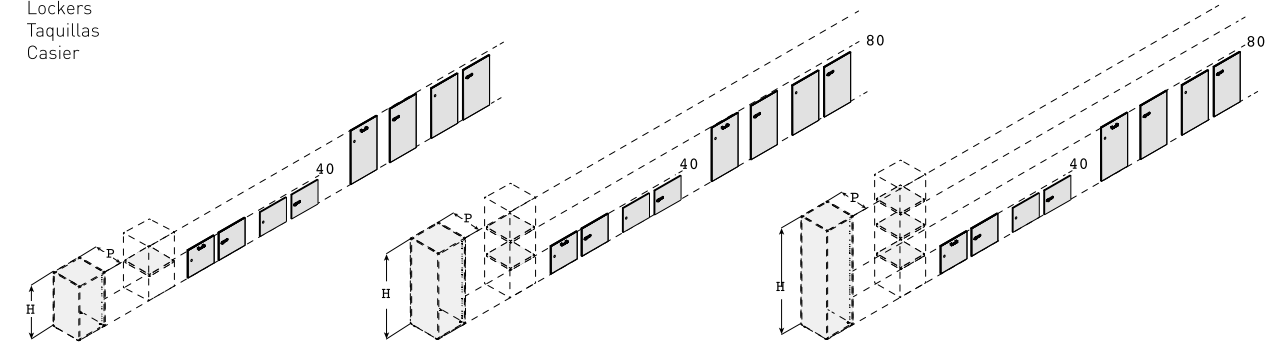

P 46 x H 81,7
L 45

P 46 x H 121,7
L 45

P 46 x H 161,7
L 45

Accessori per Lockers
Lockers accessories
Accesorios para taquillas
Accessories pour casiers

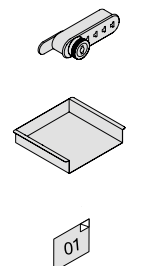

Librerie
 Bookcases
 Librerías
 Armoires

Ante melaminico
 Melamine doors
 Puertas en melamina
 Portes en mélamine

Ante vetro fumè
 Smoked glass doors
 Puertas en vidrio fumè
 Portes en verre fumè

Ante vetro acidato telaio alluminio
 Aluminium framed etched glass doors
 Puertas de vidrio ácido con marco de aluminio
 Portes en verre dépoli châssis aluminium apparent

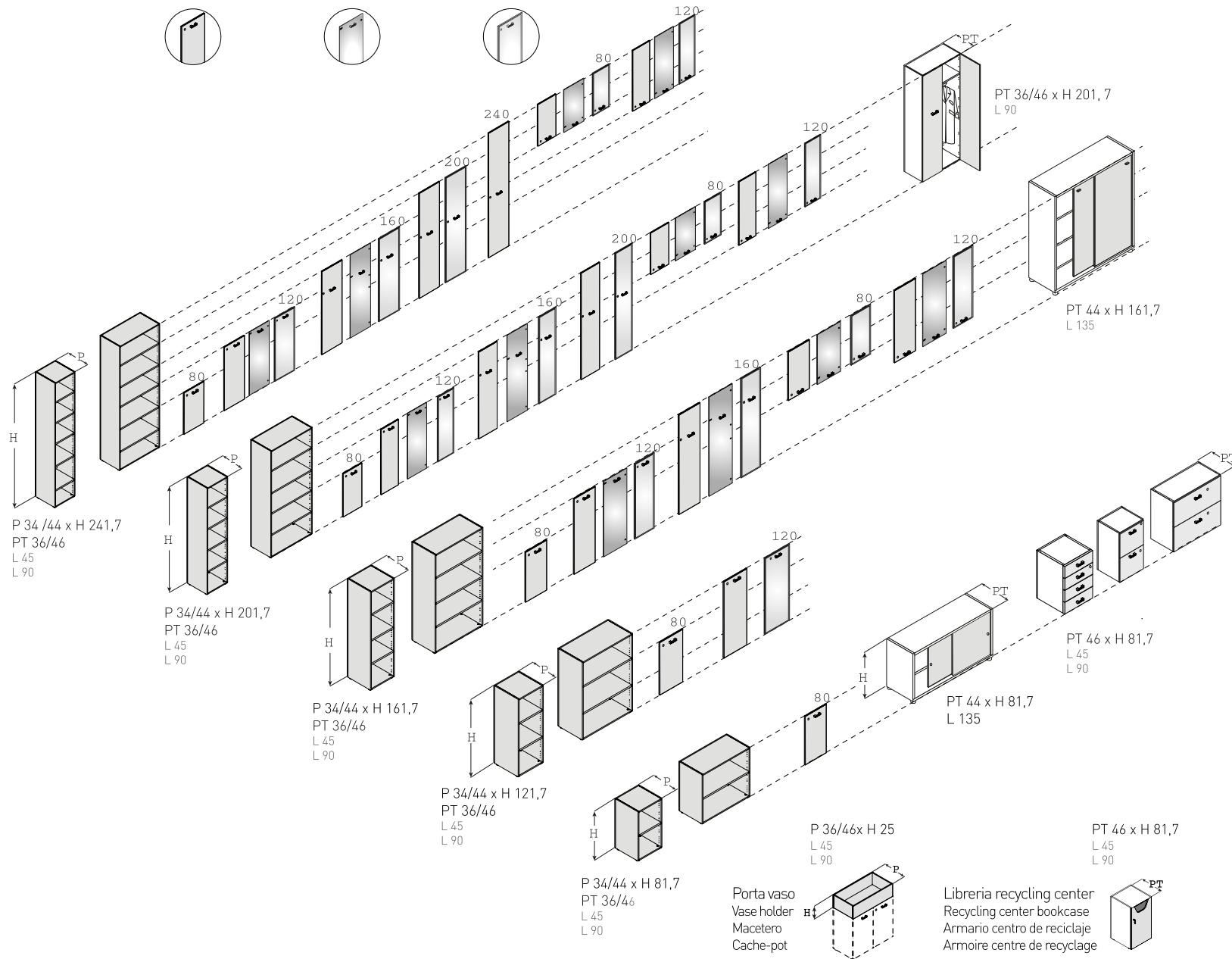

Top modulare
 Modular top
 Tapa modular
 Top modulaire

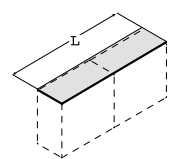

P 36,6/46,6 x H 1,8
 L 45,2
 L 90,2
 L 135,3
 L 180,3
 L 225,4
 L 270,4

Fianchi di finitura
 Finishing side panels
 Costados finales
 Cotés finaux armoire

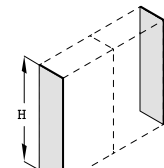

P 36,6/46,6 x H 1,8
 H 81,8
 H 121,8
 H 161,8
 H 201,8
 H 241,8

Pensili
 Wall units
 Colgantes
 Meubles suspendus

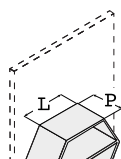

L 46,2 x P 20x H 44

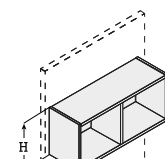

L 90 x P 31,5 x H 44

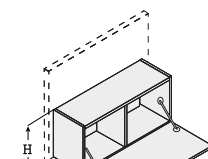

L 90 x P 33,5 x H 44

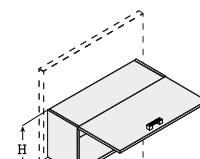

L 90 x P 33,5 x H 44

EIDOS *pro*

FINISHES

Piani in legno / Melamine tops / Sobres en melamina / Plateaux en mélamine

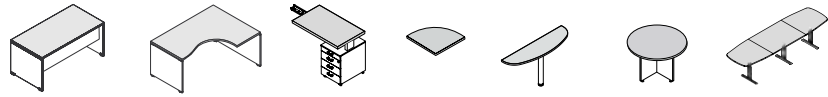

Melaminico / Melamine / Melamina / Mélamine



GC* Grigio Cosmico BT Bianco Seta GA Grigio avorio N2 Noce Corteccia

Fianchi in legno / Wooden legs / Costados en melamina / Pieds panneaux

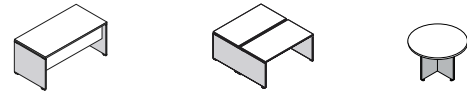

Melaminico / Melamine / Melamina / Mélamine

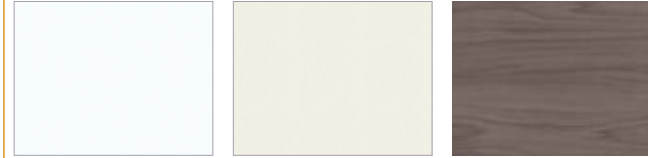

BT Bianco Seta GA Grigio avorio N2 Noce Corteccia

Gambe metallo fisse e regolabili / Metal legs / Patas metálicas / Pieds métalliques

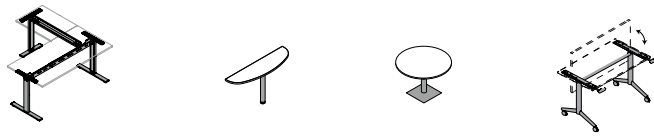

Metallo / Metal / Metal / Métal

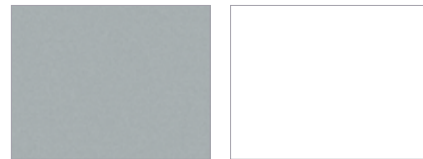

AL Alluminio BI Bianco

Strutture in metallo elevabili elettricamente / Metal structures electrically adjustable / Estructuras metálicas regulables en altura eléctricamente / Structures métalliques réglables électriques



Metallo / Metal / Metal / Métal



NE Nero BI Bianco

Cassa e top / Structure and top / Estructura y tapa / Coffre et top

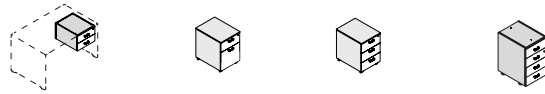

Melaminico / Melamine / Melamina / Mélamine

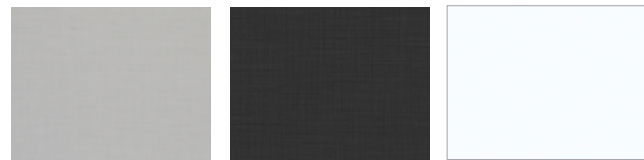

94 Alcene AA Alcene Antracite BT Bianco Seta

Frontali / Frontals / Frontales / Façade

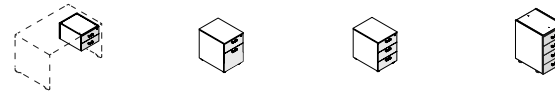

Melaminico / Melamine / Melamina / Mélamine

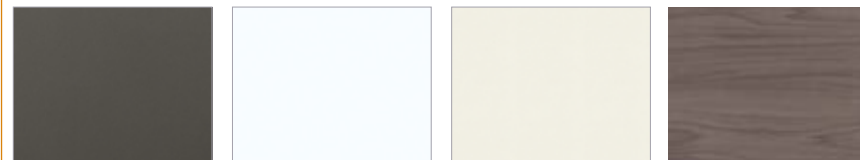

GC Grigio Cosmico BT Bianco Seta GA Grigio avorio N2 Noce Corteccia

Top e frontali / Top and frontals / Tapa y frontales / Top et façades

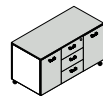

Melaminico / Melamine / Melamina / Mélamine



GC Grigio Cosmico BT Bianco Seta GA Grigio avorio N2 Noce Corteccia

Cassettiere in metallo / Metal pedestals / Cajoneras metálicas / Caissons métalliques



Melaminico / Melamine / Melamina / Mélamine

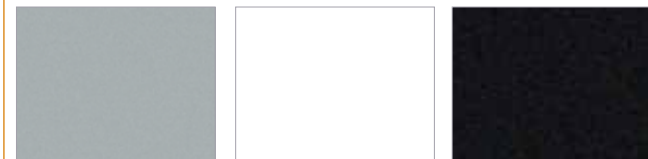

AL Alluminio BI Bianco NE Nero

Traverse e Gonne / Regular and structural modesty panels / Travesaños y faldones / Voiles de fond

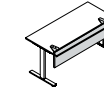

Melaminico / Melamine / Melamina / Mélamine



GC Grigio Cosmico BT Bianco Seta GA Grigio avorio N2 Noce Corteccia

Canalizzazioni e complementi / Cable management systems and accessories / Canalizaciones y complementos / Câblage et accessoires



Metallo / Metal / Metal / Métal

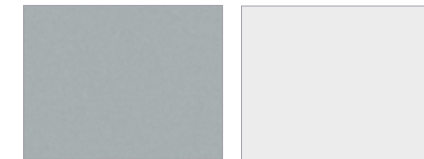

AL Alluminio ZI Zincato

Metallo / Metal / Metal / Métal

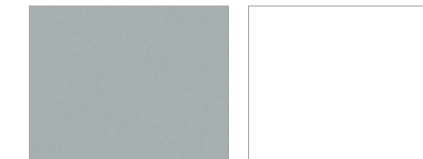

AL Alluminio BI Bianco

Schermi in melaminico / Melamine screens / Separadores en melamina / Ecrans mélamine

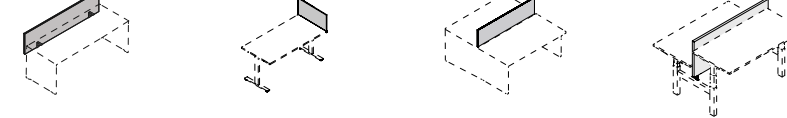

Melaminico / Melamine / Melamina / Mélamine



GC Grigio Cosmico BT Bianco Seta GA Grigio avorio N2 Noce Corteccia

Schermi in tessuto / Fabric screens / Separadores tapizados / Ecrans tissu
Schermi Fonoassorbenti / Acoustic screens / Separadores fonoabsorbentes / Ecrans acoustiques

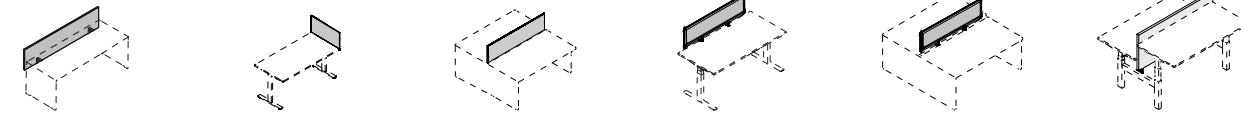

Tessuto / Fabric / Tela / Tissu



AV Avorio GR Grigio AZ Azzurro GI Giallo VE Verde RO Rosso

* Bordo effetto multistrato solo per sp.30 mm / Multilayer effect edge only for thick.30 mm / Chant effet multiplis uniquement pour épaisseur 30mm / Borde de efecto multicapa solo para espesor 30 mm

Paretine / Partitions / Separadores a suelo / Cloisons

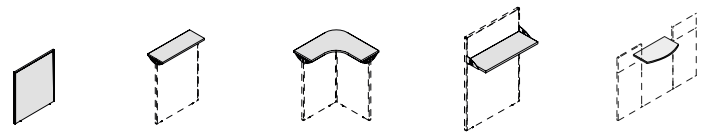

Melaminico / Melamine / Melamina / Mélamine



GC* Grigio Cosmico BT Bianco Seta GA Grigio avorio N2 Noce Corteccia

Paretine / Partitions / Separadores a suelo / Cloisons



Metallo / Metal / Metal / Métal

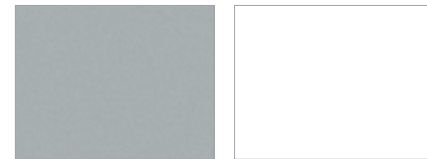

AL Alluminio BI Bianco

Vetro / Glass / Cristal / Verre



TR Trasparente

Librerie / Bookcases / Librerías / Armoires

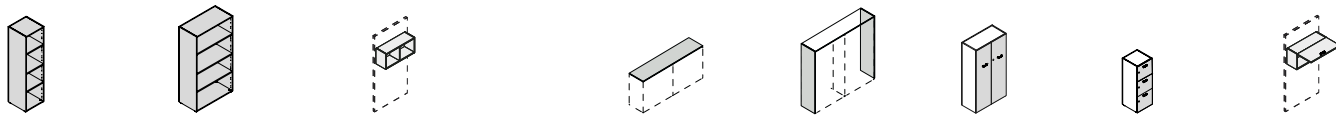

Melaminico / Melamine / Melamina / Mélamine



94 Alcene AA Alcene Antracite BT Bianco Seta GC Grigio Cosmico BT Bianco Seta GA Grigio avorio N2 Noce Corteccia

Librerie / Bookcases / Librerías / Armoires

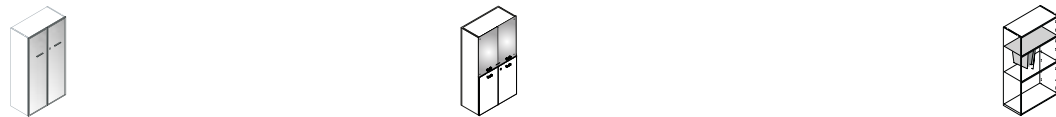

Vetro / Glass / Cristal / Verre

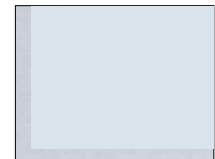

VA Vetro Acidato

Vetro / Glass / Cristal / Verre

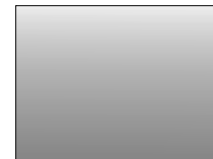

VF Vetro Fumè

Metallo / Metal / Metal / Métal

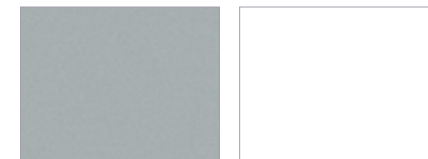

AL Alluminio BI Bianco

* Bordo effetto multistrato solo per sp.30 mm / Multilayer effect edge only for thick.30 mm / Chant effet multiplis uniquement pour épaisseur 30mm / Borde de efecto multicapa solo para espesor 30 mm

Art Director:
Ulisse Narcisi
Image:
Nerokubo
Fotolito e stampa:
www.nerokubo.com

ARANWORLD SRL U. NEL PERSEGUIRE UNA POLITICA VOLTA AL COSTANTE MIGLIORAMENTO, SI RISERVA IL DIRITTO DI APPORTARE, IN QUALSIASI MOMENTO E SENZA PREAVVISO, LE MODIFICHE AI PRODOTTI CHE RITERRA UTILI E NECESSARIE. L'EFFETTIVA DISPONIBILITÀ DI QUANTO A CATALOGO DEV'ESSERE EFFETTIVAMENTE VERIFICATA AL MOMENTO DELL'ORDINE. A CAUSA DI NATURALI LIMITI TECNICI DI RIPRODUZIONE E STAMPA, IL COLORE DEI MODELLI A CATALOGO È PURAMENTE INDICATIVO E NON PUÒ COSTITUIRE MOTIVO DI RIVALSA. ARANWORLD S.R.L. U. ASSECONDANDO LA PROPRIA VOCAZIONE ECOLOGISTA, HA ADOTTATO IL FONT CALIBRI AL FINE DI CONTRIBUIRE ULTERIORMENTE A SALVAGUARDARE IL NOSTRO PIANETA GRAZIE AL RIDOTTO CONSUMO DI TONER E CARTA GRAZIE A QUESTO ACCORGIMENTO.

THE COMPANY ACTIVELY PURSUES AN AMBITIOUS CONTINUOUS IMPROVEMENT POLICY AND IT RESERVES THE RIGHT TO MAKE AT ANY TIME AND WITHOUT PRIOR NOTICE THE CHANGES IN THE PRODUCT AS IT DEEMS USEFUL AND NECESSARY. THE ACTUAL AVAILABILITY OF THE ITEMS SHOWN IN THE CATALOGUE MUST BE VERIFIED AT THE TIME OF THE ORDER. DUE TO TECHNICAL LIMITATIONS IN NATURAL REPRODUCTION AND PRINTING, THE COLOUR OF THE MODELS IN THE CATALOGUE ARE PURELY INDICATIVE AND CANNOT BE A REASON FOR RECOURSE. THE COMPANY, FAVORING ITS ECOLOGICAL VOCATION, HAS ADOPTED THE CALIBRI FONT IN ORDER TO FURTHER CONTRIBUTE TO SAFEGUARD OUR PLANET IN REDUCING CONSUMPTION OF PAPER AND TONER THANKS TO THIS DEVICE.

ARANWORLD SRL U., PERSIGUIENDO UNA POLÍTICA DESTINADA A UNA CONSTANTE MEJORA, SE RESERVA EL DERECHO DE APORTAR, EN CUALQUIER MOMENTO Y SIN PREAVISO, LAS MODIFICACIONES A LOS PRODUCTOS QUE CONSIDERARÁ ÚTILES Y NECESARIAS. LA EFECTIVA DISPONIBILIDAD DE LO INDICADO EN EL PRESENTE CATALOGO DEBE EFECTIVAMENTE COMPROBARSE AL MOMENTO DE REALIZAR EL PEDIDO. DEBIDO A NATURALES LÍMITES TÉCNICOS DE REPRODUCCIÓN E IMPRESIÓN, EL COLOR DE LOS MODELOS DEL CATALOGO ES PURAMENTE INDICATIVO Y NO PUEDE CONSTITUIR UN MOTIVO DE INDEMNIZACIÓN. ARANWORLD S.R.L. U., SIGUIENDO SU PROPIA VOCACIÓN ECOLÓGICA, HA ADOPTADO EL FONT CALIBRI CON EL FIN DE AYUDAR ULTERIORMENTE A PROTEGER NUESTRO PLANETA, GRACIAS A LA REDUCCIÓN DEL CONSUMO DE TONER Y DE PAPEL, GRACIAS A ESTE RECURSO.

ARANWORLD SRL U. POUR POURSUIVRE UNE POLITIQUE VERS LA CONSTANT AMÉLIORATION, SE RÉSERVE LE DROIT D'APPORTER, N'IMPORTE QUAND ET SANS PRÉAVIS, LES MODIFICATIONS RETENUES UTILES ET NÉCESSAIRES. L'EFFECTIVE DISPONIBILITÉ DES ARTICLES DU CATALOGUE SERA OBJET DE VÉRIFICATION LORS DE LA COMMANDE. A' CAUSE DES LIMITES TECHNIQUES DE REPRODUCTION ET IMPRESSION, LES COLORIS DE LA GAMME ET DU CATALOGUES SONT INDICATIVES ET NE PEUVENT PAS FAIRE OBJET DE RÉCLAMATION. ARANWORLD S.R.L. U. DANS LA CIBLE DE RESPECTER SA VOCATION ÉCOLOGISTE, A UTILISÉ LE FONT CALIBRI POUR CONTRIBUER À SAUVEGARDER L'ENVIRONNEMENT DE LA PLANÈTE GRÂCE À LA RÉDUITE CONSOMMATION DE TONER ET PAPIER QUE CETTE CHOIX AMÈNE.



L'effettiva disponibilità di quanto a catalogo dev'essere effettivamente verificata al momento dell'ordine. A causa di naturali limiti tecnici di riproduzione e stampa, il colore dei modelli a catalogo è puramente indicativo e non può costituire motivo di rivalsa. Aran World S.r.l.U., assecondando la propria vocazione ecologista, ha adottato il font Calibri al fine di contribuire ulteriormente a salvaguardare il nostro pianeta grazie al ridotto consumo di toner e carta.

The company actively pursues an ambitious continuous improvement policy and it reserves the right to make at any time and without prior notice the changes in the product as it deems useful and necessary. The actual availability of the items shown in the catalogue must be verified at the time of the order. Due to technical limitations in natural reproduction and printing, the colour of the models in the catalogue are purely indicative and cannot be a reason for recourse. Aran World S.r.l.U., favoring its ecological vocation, has adopted the Calibri font in order to further contribute to safeguard our planet in reducing consumption of paper and toner thanks to this device.

Aran World S.r.l.U., persiguiendo una política destinada a una constante mejora, se reserva el derecho de aportar, en cualquier momento y sin preaviso, las modificaciones a los productos que considerará útiles y necesarias. La efectiva disponibilidad de lo indicado en el presente catálogo debe efectivamente comprobarse al momento de realizar el pedido. Debido a naturales límites técnicos de reproducción e impresión, el color de los modelos del catálogo es puramente indicativo y no puede constituir un motivo de indemnización. Aran World S.r.l.U., siguiendo su propia vocación ecológica, ha adoptado el font Calibri con el fin de ayudar ulteriormente a proteger nuestro planeta, gracias a la reducción del consumo de tóner y de papel.

Aran World S.r.l.U. pour poursuivre une politique vers la constant amélioration, se réserve le droit d'apporter, n'importe quand et sans préavis, les modifications retenues utiles et nécessaires. L'effective disponibilité des articles du catalogue sera objet de vérification lors de la commande. A' cause des limites techniques de reproduction et impression, les coloris de la gamme et du catalogues sont indicatives et ne peuvent pas faire objet de réclamation. Aran World S.r.l.U., dans la cible de respecter sa vocation écologiste, a utilisé le font Calibri pour contribuer à sauvegarder l'environnement de la planète grâce à la réduite consommation de toner et papier que cette choix amène.